

# BUTTERFLY VALVE WITH HANDLE

## TECHNICAL PASSPORT

### BUTTERFLY VALVE - DUCTILE IRON BODY WITH HANDLE - BETWEEN FLANGES PN10/16

VPG 4448-02

#### APPLICATION

VPG butterfly valves are intended for ON/OFF or control use in fluid transfer circuits.

- **Area of use:** water supply, water treatment, pumping, irrigation, industry.



- **Fluids :** cold water, hot water, wastewater, liquid discharges, etc.  
«Not suitable for steam application»

#### GENERAL CHARACTERISTICS

**Range :** from DN40 to DN300.

- Design according to NF EN 593.
- Type with smooth ears
- Sealing in both directions of circulation of the piping.
- Soft sleeve guaranteeing a perfect tightness.
- Extended neck compatible with pipe lapping
- Disc profiled and reduced in thickness
- Reduced maneuvering torque.
- Coupling stem on disc assembled by conical pin.
- Reduced head losses.
- Notched sector providing 10 positions of adjustment of the handle.
- With ISO 5211 mounting plate.



#### STANDARDS

<b>Design</b>	Manufacture according to the requirements of the European directive 2014/68/UE «Equipment under pressure»: modulate H.
<b>Face to face</b>	Face to face according to standards NF EN 558-1 serie 20, ISO 5272 serie 20, DIN 3202.
<b>Connection</b>	Mounting between flanges ISO PN10/16 according to EN1092-2 and GOST PN10/16. Adjustable between flanges ASME B16.5 Class 150.
<b>Tests</b>	Pressure test according to standards EN12266-1, DIN 3230 and ISO 5208: -Body : 24 bar -Seat : 17.6 bar

#### PRODUCT APPROVALS

**CE** **ERC**  on request

#### Tecofi France

83 rue Marcel Mérieux - 69960 Corbas  
Tél. +33 (0)4 72 79 05 79 - Fax. +33 (0)4 78 90 19 19  
E-mail : sales@tecofi.fr - [www.tecofi.fr](http://www.tecofi.fr)



# BUTTERFLY VALVE WITH HANDLE

## TECHNICAL PASSPORT

VPG 4448-02

### CONSTRUCTION

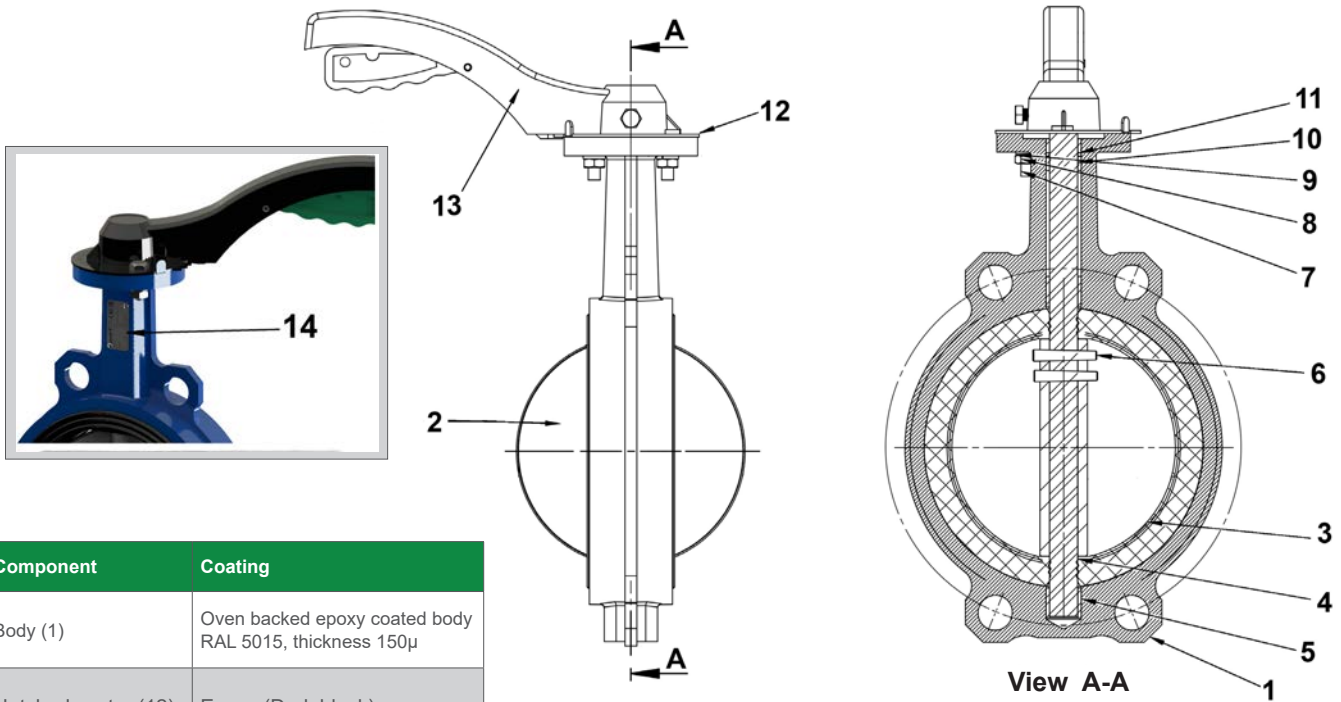

Component	Coating
Body (1)	Oven backed epoxy coated body RAL 5015, thickness 150µ
Notched sector (12)	Epoxy (Dark black)
Handle (13)	Epoxy (Dark black) + époxy RAL6024 on lever

Pos.	Q-ty	Description	Material	Equivalences		
				DIN	ASTM	BS
1	1	Body	Ductile iron EN-GJS-400-15	GGG40	A536 65-45-12	EN-JS1030
2	1	Disc	Ductile iron EN-GJS-400-15 + Nickel	GGG40	A536 65-45-12	EN-JS1030
3	1	Sleeve	Heat EPDM			
4	1	Stem	Stainless steel 420	X20Cr13		
5	2	Bushing	PTFE			
6	n	Pin	Stainless steel 420	X20Cr13		
7	2	Screw	Stainless steel 201			
8	2	Nut	Stainless steel 201			
9	2	Washer	Stainless steel 201			
10	2	Bushing	PTFE			
11	1	O ring	EPDM			
12	1	Notched sector	Steel			
13	1	Handle	Aluminium (DN40-150) Ductile iron (DN200-300)			
14	1	Nameplate	Stainless steel 304			

n=1 (DN40-125); 2 (DN150-300)

### Tecofi France

83 rue Marcel Mérieux - 69960 Corbas  
Tél. +33 (0)4 72 79 05 79 - Fax. +33 (0)4 78 90 19 19  
E-mail : sales@tecofi.fr - [www.tecofi.fr](http://www.tecofi.fr)



## BUTTERFLY VALVE WITH HANDLE

### TECHNICAL PASSPORT

VPG 4448-02

#### DIMENSIONS

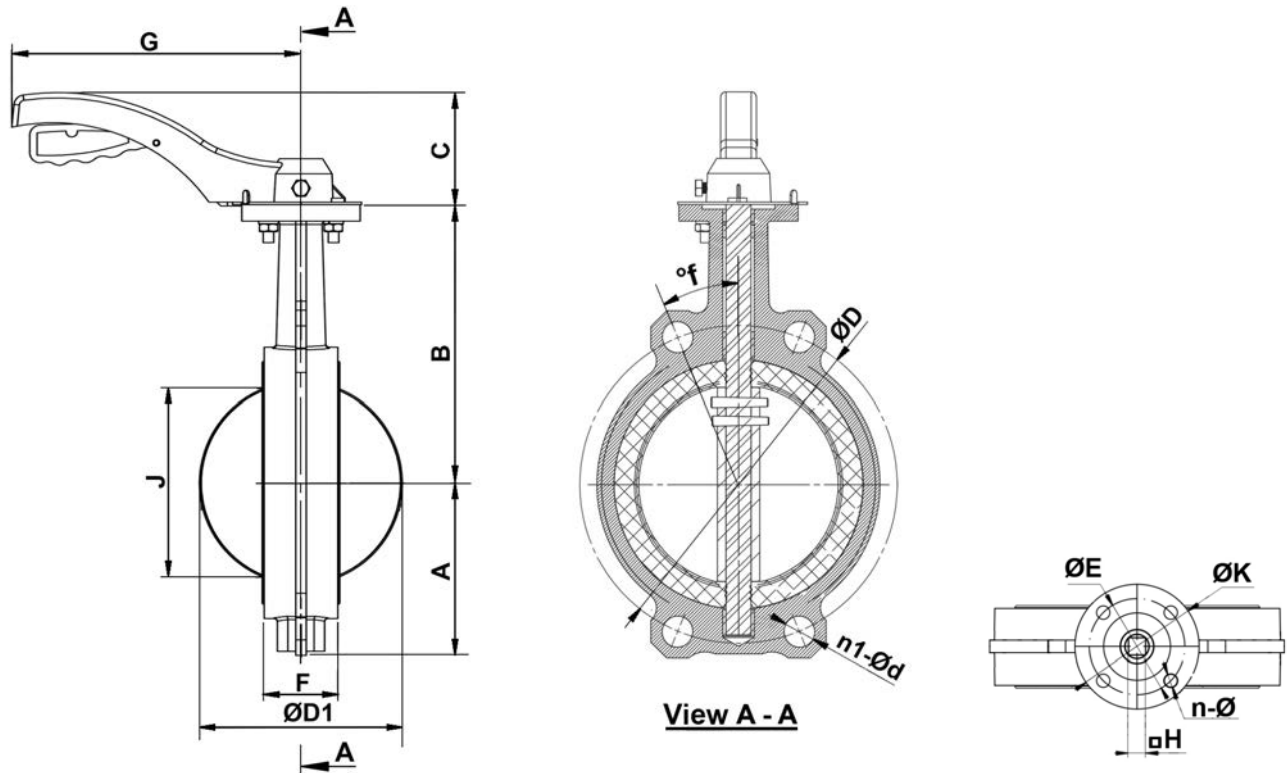

DN		A	B	C	ØD	ØD1	n1-Ød	f°	ØE	F	ØK	J	n-Ø	G	H	Torque (Nm)	Weight (kg)
mm	inch																
40	1"1/2	60	120	75	110	43	4-Ø19	45°	50	33	65	29	4-Ø7	170	9	12	1.6
50	2"	60	128	78	125	53	4-Ø19	45°	50	43	65	31	4-Ø7	170	9	16	2.1
65	2"1/2	72.5	140	78	145	65	4-Ø19	45°	50	45	65	46	4-Ø7	170	9	18	2.5
80	3"	91	148	78	160	79	4-Ø19	45°	50	45	65	64	4-Ø7	170	9	25	3
100	4"	108	165	78	180	105	4-Ø19	22.5°	50	52	65	91	4-Ø7	170	11	42	3.8
125	5"	121	175	98	210	124	4-Ø20	22.5°	70	56	90	111	4-Ø10	215	14	65	6
150	6"	131	199	98	240	155	4-Ø23	22.5°	70	56	90	144	4-Ø10	215	14	110	7.3
200	8"	163	220	93	295	203	4-Ø23	15°/22.5°	102	60	125	194	4-Ø12	350	17	200	12.9
250	10"	198	251	93	350/355	251	4-Ø28	15°	102	68	125	242	4-Ø12	350	22	330	19
300	12"	231	288	109	400/410	302	4-Ø28	15°	102	78	125	292	4-Ø12	500	22	500	30

The smooth holes are oblong on the DN40, DN200 et DN300 (Radius 12 mm et 13.5 mm)

#### WORKING CONDITIONS

Maximum working pressure : 16 bar  
(6 bar for compressed air)

Maximum vacuum pressure : -0.8 bar for 10 minutes (vacuum tests performed in October 2021, valve tested open at -0.8 bar for 10 minutes)

Maximum working temperature : -10°C / +130°C

#### Tecofi France

83 rue Marcel Mérieux - 69960 Corbas  
Tél. +33 (0)4 72 79 05 79 - Fax. +33 (0)4 78 90 19 19  
E-mail : sales@tecofi.fr - [www.tecofi.fr](http://www.tecofi.fr)

