

## KNIFE GATE VALVE DUCTILE IRON BODY

TECHNICAL PASSPORT

### KNIFE GATE VALVE WITH GEARBOX RISING STEM DUCTILE IRON BODY - WAFER TYPE PN10

VG 6400-08

#### APPLICATION

The knife gate valve is particularly suitable for the most difficult applications.

**Area of use:** water treatment networks, pulp and paper industry, chemical plants, winemaking, cement works, pneumatic transport, storage.



**Fluids:** water, sewage, pulp, pasty products, powdery, granular, fibrous, abrasive and crystallizing.

#### GENERAL CHARACTERISTICS

**Range:** from DN350 to DN600.

- Knife Gate Valve on/off or regulation with rising stem.
- Molded monobloc body
- Unidirectional water tightness: Flow direction indicated on the body with an arrow.
- Installation between flanges ISO PN10.
- Small retention zone.
- Gate with a beveled cutting edge guided in the body with little backlash.
- Guaranteed closure, without risk of blockage.
- Standard polished gate, soft contact with the gaskets.
- Very resistant ductile iron packing flange avoids risks of breaks.
- Operating force reduced thanks to the elasticity of the gaskets.
- Full flow when fully opened, ensuring a high flow rate with low head loss.
- Flow regulation possible for pasty or abrasive fluids with installation of a deflector.



#### STANDARDS

<b>Design</b>	Manufacture according to the requirements of the European directive n° 2014/68/UE «Equipment under pressure» : modulate H. In option: product conform to European directive ATEX «ATmosphère EXplosive» n° 2014/34/UE.					
<b>Face to face</b>	Face to face dimension according to TECOFI standard					
<b>Connection</b>	Mounting between flanges in accordance with EN1092-2 and DIN 2501 : ISO PN10					
<b>Tests</b>	Pressure test according to standards EN12266-1, DIN 3230 and ISO 5208.					
	DN	Body	Seat	DN	Body	Seat
	DN350-450:	12.6 bar	7.7 bar	DN500-600:	7.2 bar	4.4 bar

#### PRODUCT APPROVALS



#### Tecofi France

83 rue Marcel Mérieux - 69960 Corbas  
Tél. +33 (0)4 72 79 05 79 - Fax. +33 (0)4 78 90 19 19  
E-mail : sales@tecofi.fr - [www.tecofi.fr](http://www.tecofi.fr)



## KNIFE GATE VALVE DUCTILE IRON BODY

### TECHNICAL PASSPORT

VG 6400-08

#### CONSTRUCTION

The valves are coated with epoxy paint to protect them against corrosion

Component	Coating
Support plate (8)	Liquid epoxy RAL 6005 70 microns
Handwheel (17)	Liquid epoxy RAL 9005 70 microns
Protection tube (18)	Liquid epoxy RAL 9005 70 microns

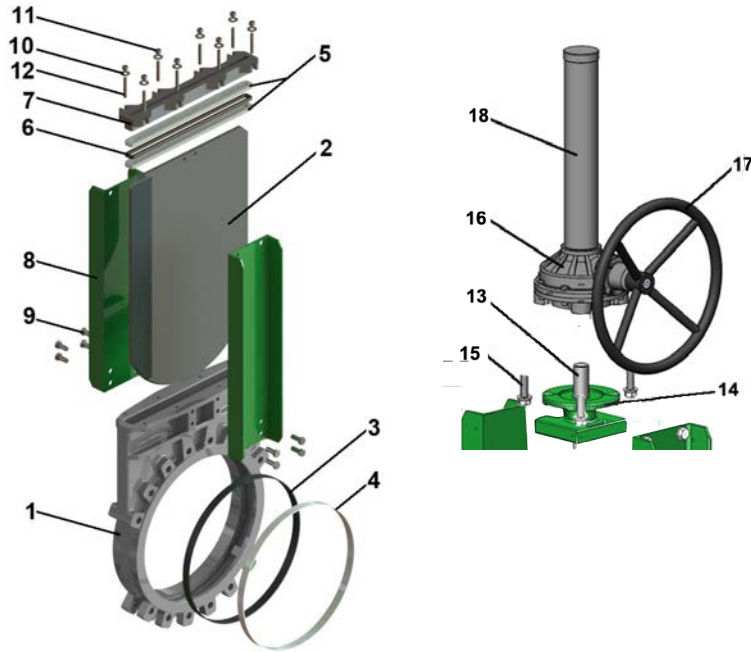

Pos.	Q-ty	Description	Material	Equivalences		
				DIN	ASTM	BS
1	1	Body	Stainless steel GX5CrNiMo 19-11-2	G-X6CrNiMo18 10	A 351 grade CF8M	316 C16
2	1	Gate	Stainless steel X5CrNiMo 17-12-2	X2CrNiMo17-13-2	A 182 AISI 316L	1449-2 316 S11
3	1	Seat gasket	EPDM			
4	1	Support ring (1)	Stainless steel X5CrNiMo 17-12-2	X5CrNiMo18 10	A 182 AISI 316	1449-2 316 S16
5	2	Packing	PTFE			
6	1	O-Ring	EPDM			
7	1	Packing gland	Stainless steel GX5CrNiMo 19-11-2	G-X6CrNiMo18 10	A 351 grade CF8M	316 C16
8	2	Support plate	Steel			
9	12	Screw	Stainless steel A2-70			
10	8	Washer	Stainless steel A2-70			
11	8	Nut	Stainless steel A2-70			
12	8	Tie rod	Stainless steel A2-70			
13	1	Stem	Stainless steel 13% Cr	X12Cr13	AISI 410	
14	1	Mounting plate	Ductile iron EN-GJS-500-7	GGG 50	A536 65-70-50-05	1563 EN-JS1050
15	1	Screw	Stainless steel A2-70			
16	2	Gearbox				
17	1	Handwheel	Cast iron EN-GJL-250	GG25	A48 class 40B	1452 Grade 250
18	1	Protection tube	Steel A45			

(1) - Parts missing on metal/metal sealing

**Tecofi France**

83 rue Marcel Mérieux - 69960 Corbas  
Tél. +33 (0)4 72 79 05 79 - Fax. +33 (0)4 78 90 19 19  
E-mail : sales@tecofi.fr - [www.tecofi.fr](http://www.tecofi.fr)



## KNIFE GATE VALVE DUCTILE IRON BODY

### TECHNICAL PASSPORT

VG 6400-08

#### DIMENSIONS

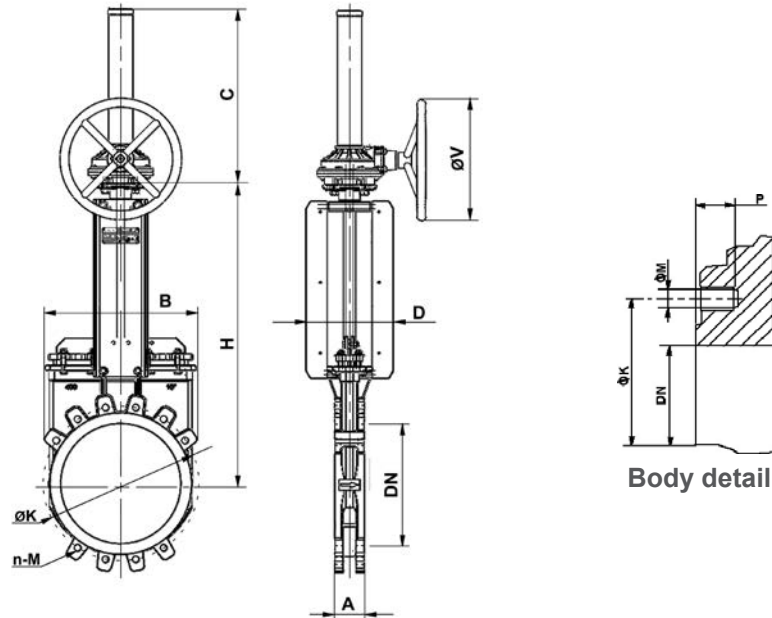

DN		A	B	C	D	H	ØK	P	n-M	Number of through holes	Ø V	Weight (kg)
mm	inch											
350	14"	96	438	578	290	892	460	20	10XM20	16	500	135
400	16"	100	494	578	290	999.5	515	24	10XM24	16	500	169
450	18"	106	547	630	290	1087.5	565	24	14XM24	20	500	205
500	20"	110	613	680	290	1199.3	620	24	14XM24	20	500	223
600	24"	110	716	780	290	1408	725	24	14XM27	20	500	310

Dimension A - face to face according to TECOFI standard

#### TYPES OF CONSTRUCTION

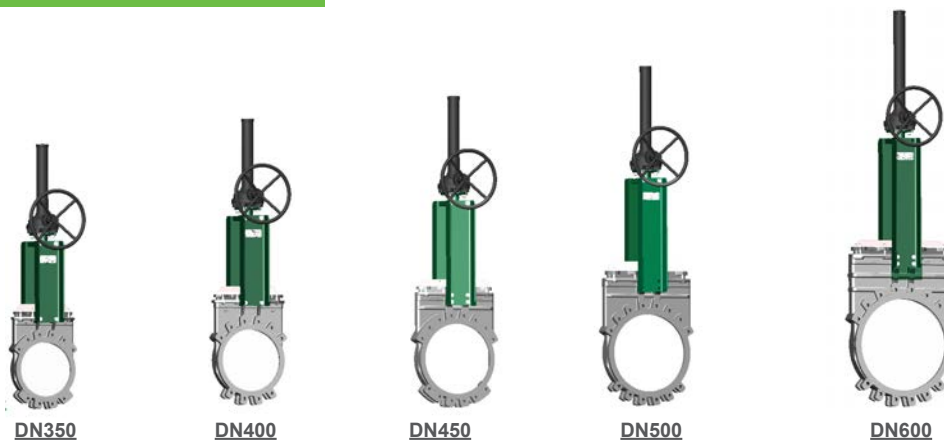

**Tecofi France**

83 rue Marcel Mérioux - 69960 Corbas  
Tél. +33 (0)4 72 79 05 79 - Fax. +33 (0)4 78 90 19 19  
E-mail : sales@tecofi.fr - [www.tecofi.fr](http://www.tecofi.fr)



The photographs and technical art works are not contractual. The specifications of the presented products are open to modifications without previous advice

# KNIFE GATE VALVE DUCTILE IRON BODY

## TECHNICAL PASSPORT

**VG 6400-08**

### WORKING CONDITIONS

Maximum working pressure: DN350-450 : 7 bar  
DN500-600 : 4 bar

Maximum working temperature : -10°C / +130°C (EPDM joint in standard)

**⚠** The above mentioned pressures are only valid if the direction of assembly indicated by the arrow on the valves is observed.

#### Upstream/downstream tightness



Elastomer  
tightness

Metal/metal  
tightness

#### Packing tightness

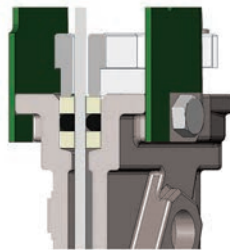

PTFE/Elastomer

#### Tightness in option

Tightness	maximum temperature
Metal/metal	Tmax : -10°C / +80°C
NBR	Tmax : -10°C / +80°C
White EPDM	Tmax : -10°C / +130°C
Silicone	Tmax : -10°C / +170°C
FPM (Type Viton®)	Tmax : -10°C / +170°C
PTFE	Tmax : +4°C / +170°C
CSM (Type Hypalon ®)	Tmax : +4°C / +80°C

**⚠** To ensure a satisfactory tightness, when using the PTFE gasket, the operating pressure must be at least 1 bar.

### FLOWS

#### Kv of valves (m<sup>3</sup>/h)

DN		Operating stroke, %									
mm	inch	10%	20%	30%	40%	50%	60%	70%	80%	90%	100%
350	14"	218,4	725,8	1323	2173,2	3294,8	4914,3	7120,9	11415,3	19105,4	24890,7
400	16"	389,1	1150,1	2024,4	3130,9	4669,6	7009,1	10355,2	16014,2	22600,5	26497,7
450	18"	402,7	1287,3	2402,9	3803,4	5686,8	8247,3	12248,7	17298,5	26403,9	29485
500	20"	617	1611,1	2935,9	4625,8	7054,7	10438,9	15446	23582,8	35107,4	42784

**Tecofi France**

83 rue Marcel Mérieux - 69960 Corbas  
Tél. +33 (0)4 72 79 05 79 - Fax. +33 (0)4 78 90 19 19  
E-mail : sales@tecofi.fr - [www.tecofi.fr](http://www.tecofi.fr)

