

SIDE MOUNTED VACUUM RELIEF

PIPED VENTS
PRESSURE RELIEF (bottom mount) OR
VACUUM RELIEF (side mount)

401

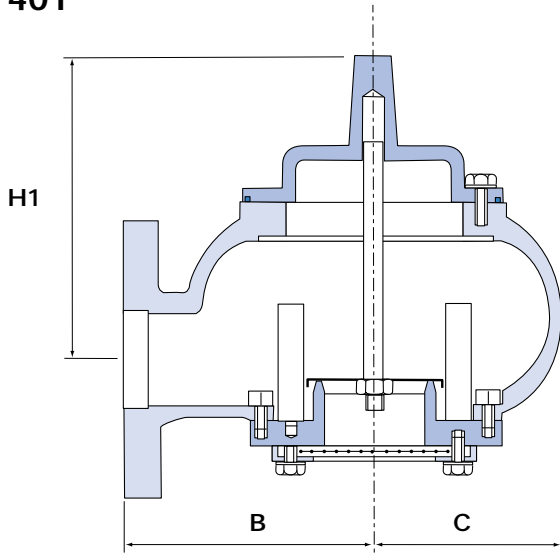

501

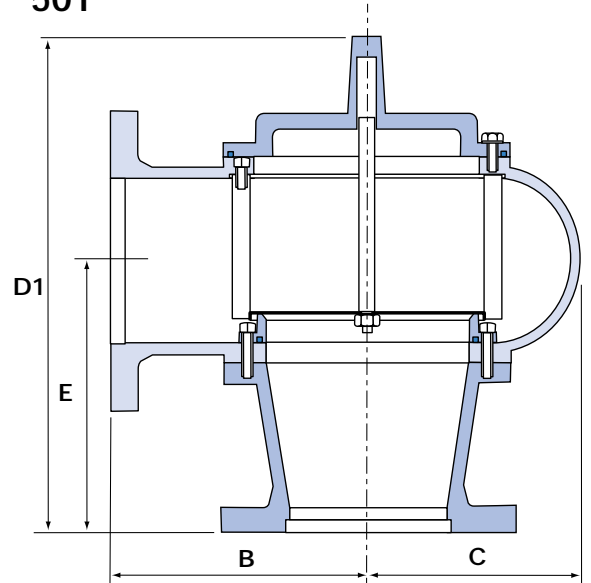

451

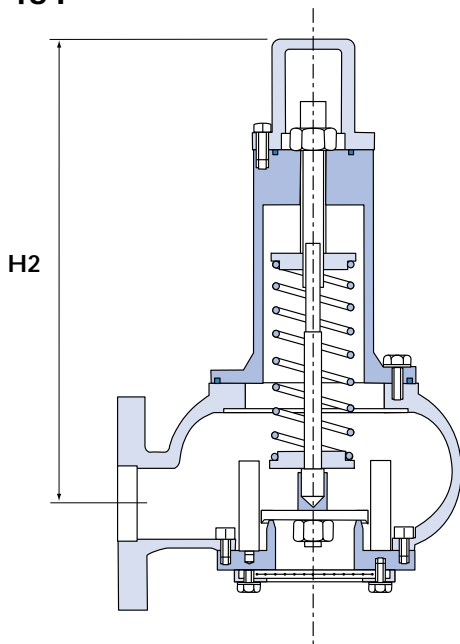

551

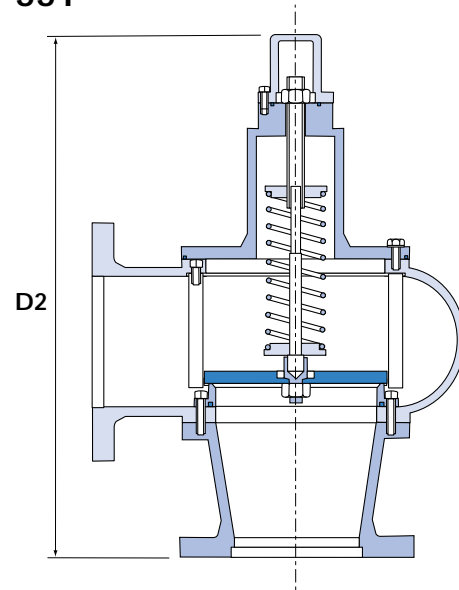

VALVE SIZE	DIMENSIONS mm							APPROXIMATE WEIGHTS - Kgs							
	B	C	D1	D2	E	H1	H2	401		451		501		551	
								ALUM	CS/SS	ALUM	CS/SS	ALUM	CS/SS	ALUM	CS/SS
DN50 (2")	140	105	308	472	142	166	330	4	11	9	17	6	16	11	22
DN80 (3")	180	140	370	518	184	179	334	6	22	11	42	9	30	14	50
DN100 (4")	200	162	424	563	212	202	351	10	35	16	55	14	60	20	80
DN150 (6")	242	202	483	635	274	200	361	17	48	32	83	24	85	39	120
DN200 (8")	310	237	557	696	329	217	361	26	72	41	107	36	115	50	150
DN250 (10")	358	280	605	773	355	230	418	39	101	59	137	55	144	75	180
DN300 (12")	393	326	653	798	363	300	435	51	135	71	200	72	196	92	260
DN400 (16")	510	417	989	997	572	417	435	110	420	140	480	190	620	220	680